

Xero 4

Assembly and operating instructions

visplay

play it smart

Visplay products are manufactured according to the latest technology and comply with valid rules and regulations.

Nevertheless, these products can cause injury or damage if:

- the product is improperly installed
- the product is improperly used
- the product is improperly altered or modified
- original accessories are not used
- the safety regulations are not observed.

⚠ WARNING

Each person involved in the planning, installation and/or use of our products must be carefully read and observe these instructions of use.

The following are of course also valid:

- Relevant accident prevention regulations
- Generally recognized safety rules
- National regulations – please consult Visplay if there is a discrepancy with the Assembly manual

Safety instructions

⚠ WARNING

When playing, children often incorrectly assess danger. You must therefore make sure that your store fittings are not used as toys.

Please pay attention to the following points:

- Structural conditions, in particular the design and bearing capacity of walls, ceilings and floors. If bearing capacity for the specified tractive or pressure load cannot be achieved by suitable fastening or stabilising elements, please refrain from installation.
- All the structural components supplied for stabilising structures are to be used in an unrestricted manner and must not be removed.
- The products may only be loaded after all the installation steps have been completed.
- Merchandise supports should be loaded as evenly as possible.
- Avoid loading in fits and starts.
- The maximum weight loads is to be observed. This can be found in the instructions on assembly and use, as well as in our sales documentation.
- Furniture with castors is generally much more unstable than furniture with glides. Tall, heavy structures on castors should thus be avoided.
- The recommendations of your safety officer should also be observed.

General care for chrome, silk and pearl

In clothing retail applications, frequent dragging of clothes hangers along the surface can cause slight abrasion to their hooks. This effect is most pronounced - more so than with front-on horizontal or inclined-pole displays - where garments are hung side-on such that hangers have to be moved more frequently. To prevent garments from becoming soiled, cleaning of the hanging rods is essential.

This abrasion can be considerably reduced by using a

coat hanger cover (scliss, 929-449.02).

No responsibility can be accepted for damage caused by soiling, as the above mentioned abrasion depends on the material of the coathangers in use.

With powder-coated surfaces subject to frequent use, use of special paints is recommended. We will be happy to advise you.

Use and care of merchandise supports with anodised aluminium surfaces

Visplay merchandise supports with anodised aluminium surfaces are hard-wearing. However, the exchange of accessories might cause slight marks on the surface. Accessories with plastic inserts usually cause less wear or none at all.

To remove the marks, we recommend using cleaning agents ranging from pH 5–8 (do not use any detergents with acidic or alkaline reaction). Clean by washing the surfaces using a sponge and water containing a wetting agent. Then remove any loose or greasy dirt. Rubbing off the surfaces with detergent using pure cotton waste or porous cleaning tissue and applying the necessary pressure in rubbing direction will remove the marks.

Aluminium profiles with widths exceeding 200 mm must be subjected to abrasive cleaning using detergents specifically developed for this purpose. The cleaning agents developed for abrasive cleaning contain very finely ground neutral polishing agents and have to be adapted to the oxide layer. Alternatively, cleaning can be carried out using an abrasive fibrous web (e.g. Scotch-Brite, type A, red, fine or very fine) in combination with a non-abrasive detergent.

Subsequently, residual cleaning agents should to be rinsed off using a sponge and clear water. Then rub off the part with a chamois.

Assembly dimensions / Layout

Xero Aluminium extrusions can be hung on various bases on the wall and in mid-floor.
All ranges of accessories in chrome and silk can be used.

! Powder-coated accessories can not be used.

! Please observe the indications concerning weight loading and ensure that the substructure of the wall units/furniture and their fixtures can support the expected loads.
With free-standing furniture, ensure that there is sufficient stability even with the intended merchandise supports.

Assembly dimensions

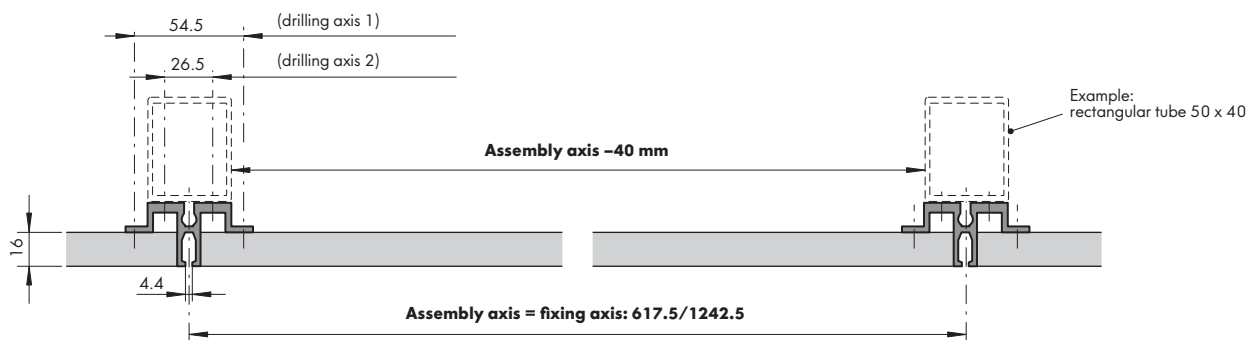
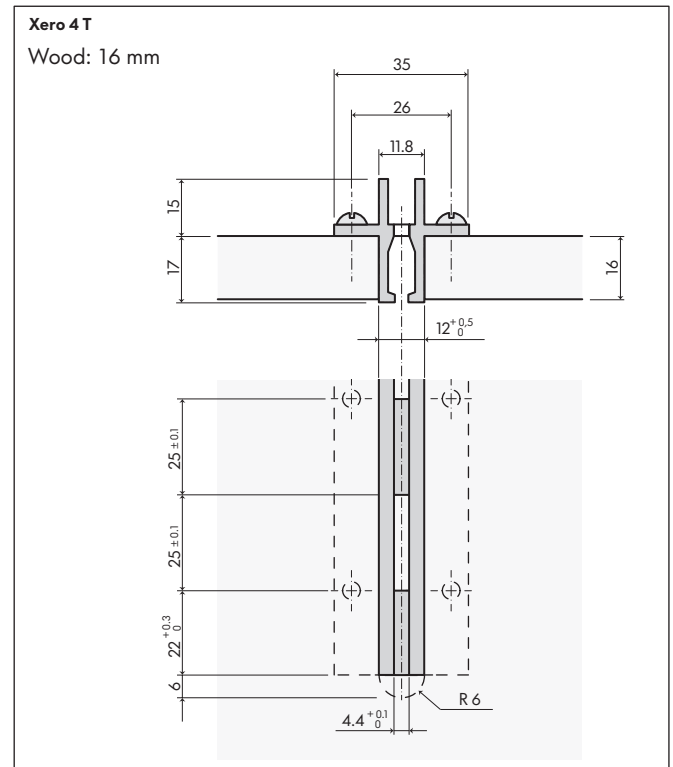
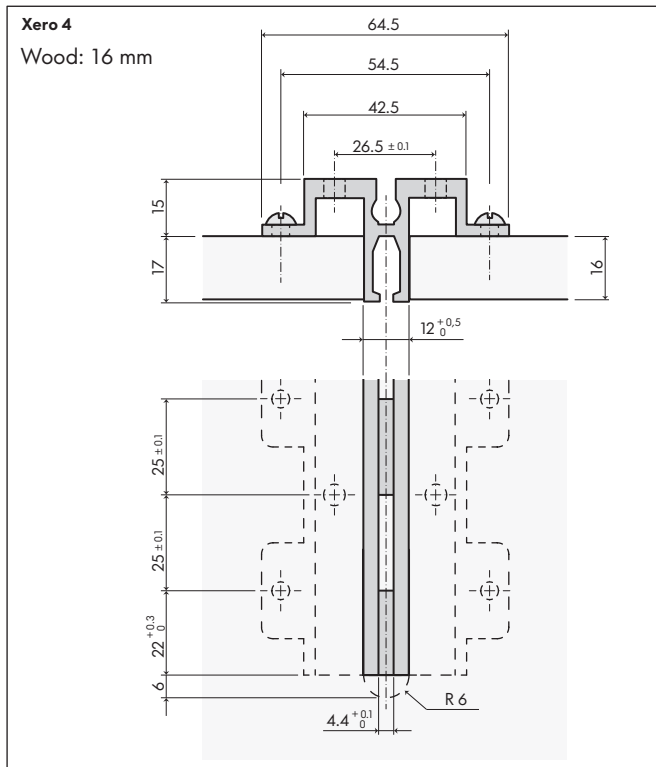

! Please note the different assembly axes. With Xero profiles, accessories cannot be used over two axes.

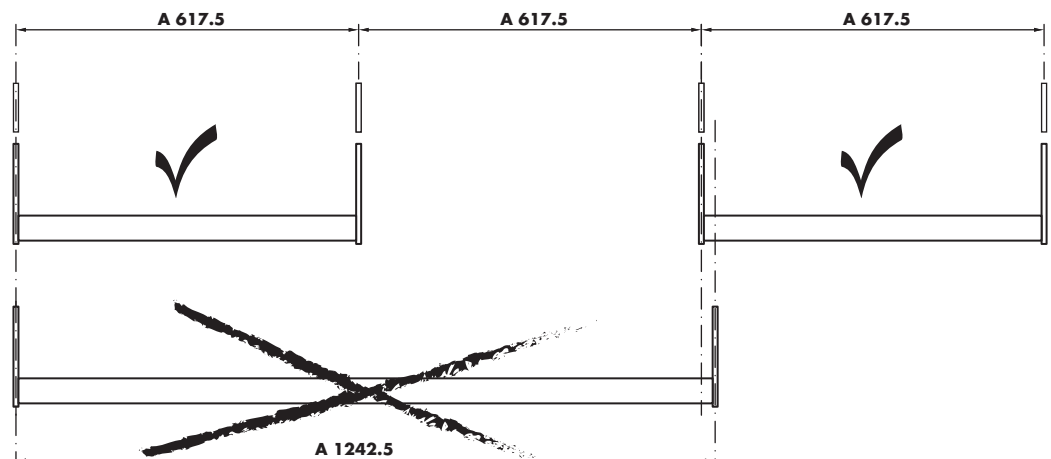

Layout

Panels and sub-structures must be toughened against bowing. Wooden ledges or angle sections are suitable for this purpose.

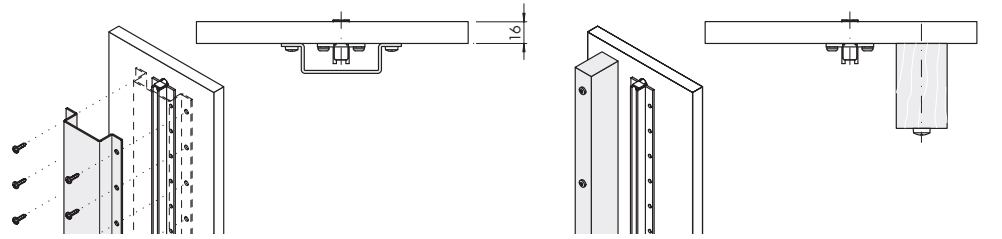

Recommendation for grid arrangement

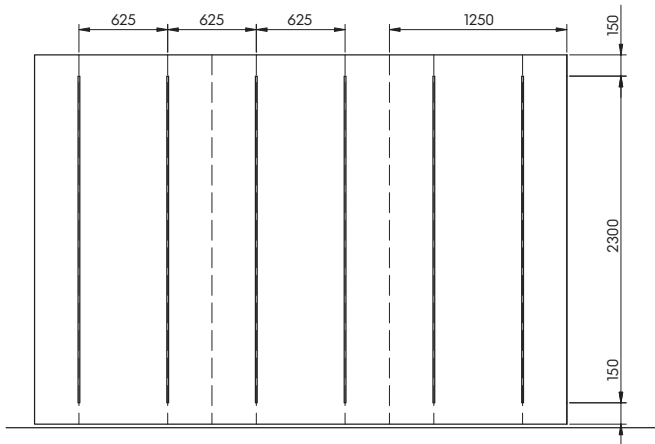

Xero 4 (A 625 mm) Accessories Xero 4 (ø 25/L. 1245 mm)

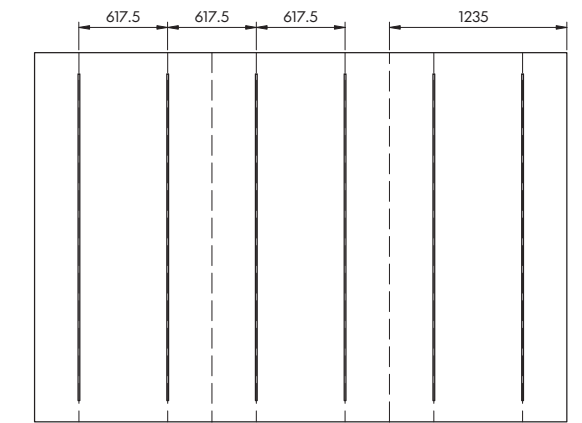

Xero 4 (A 617.5 mm) + Accessories + Accessories Xero 4 (L. 1230 mm)

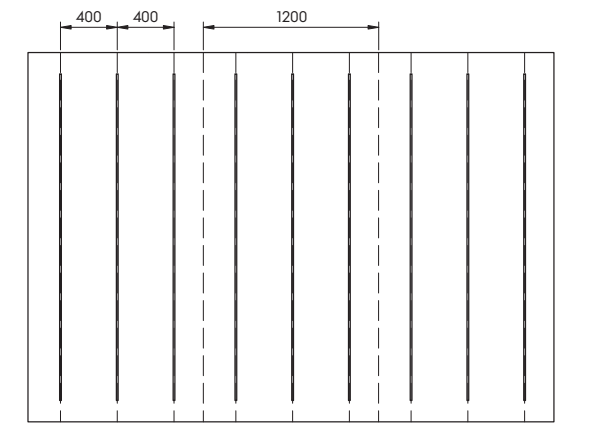

Xero 4 (A 400 mm) + Accessories Xero 4 (ø 12/L. 795 mm)

Inserting the panels into Xero 4 profile

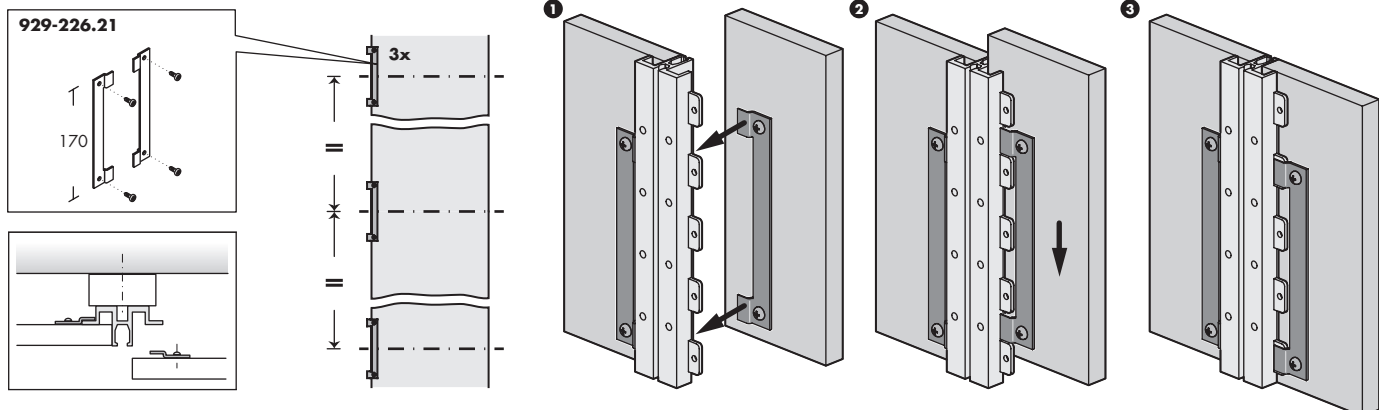

Assembly instructions

❗ The aluminium profile must be fixed to the panel.

Assembly on wooden panels

Screw the profile Xero 4 or Xero 4 T on to the panel from the rear. Fit fixing sets to the Xero 4 profile (1) or wooden ledges (2). The wooden ledge (2) must be fixed to the panel (glued and screwed) near the Xero 4 T profile. Fix the profile end caps above and down to the profile, before the profile is installed to the panel.

Xero 4

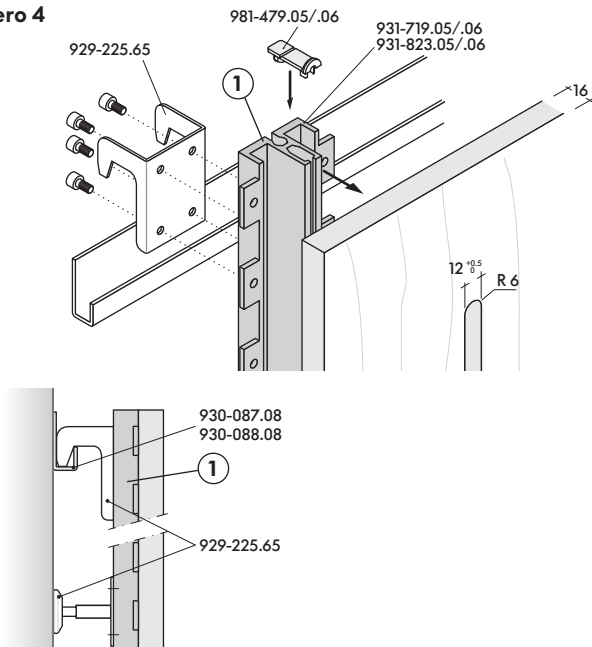

Xero 4 T

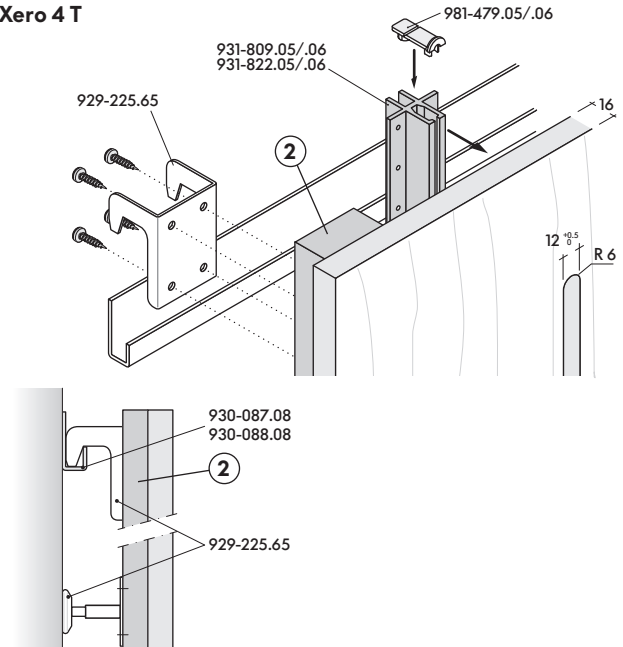

❗ Please note that the fixing set 929-225.65 cannot be attached to Xero 4 T profiles. Panels with these profiles are to be attached to the wall e.g. with wedge gibs. Please observe the indications concerning weight loading and ensure that the substructure of the wall units and their fixtures can support the expected loads.

Shelf dimension for bracket 342-830.31

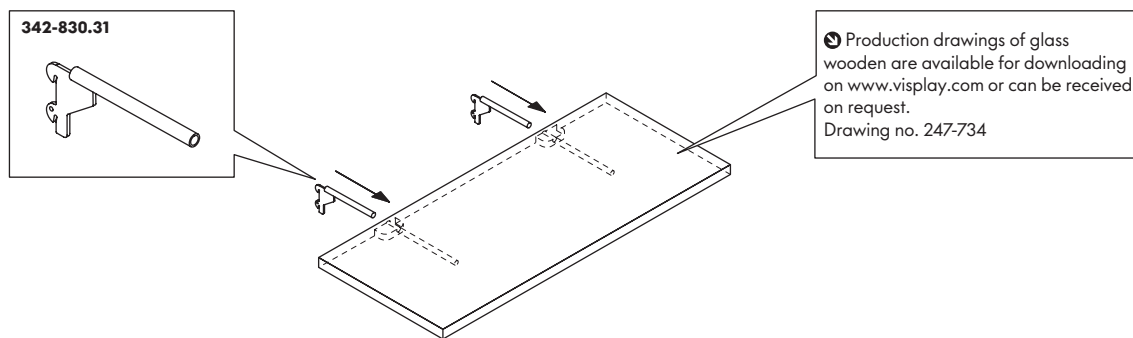

Shelf dimension for single bracket 362-079.31

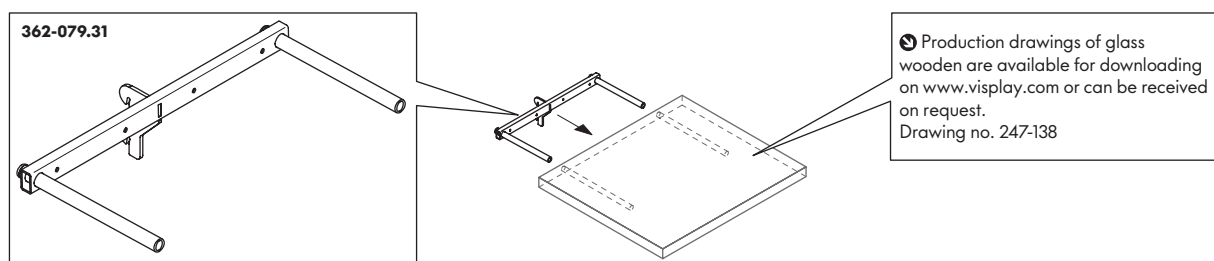

Assembly in plasterboard

⚠ Please observe the indications concerning weight loading and ensure that the substructure of the wall units/furniture and their fixtures can support the expected loads.

1. Assembling wall upright

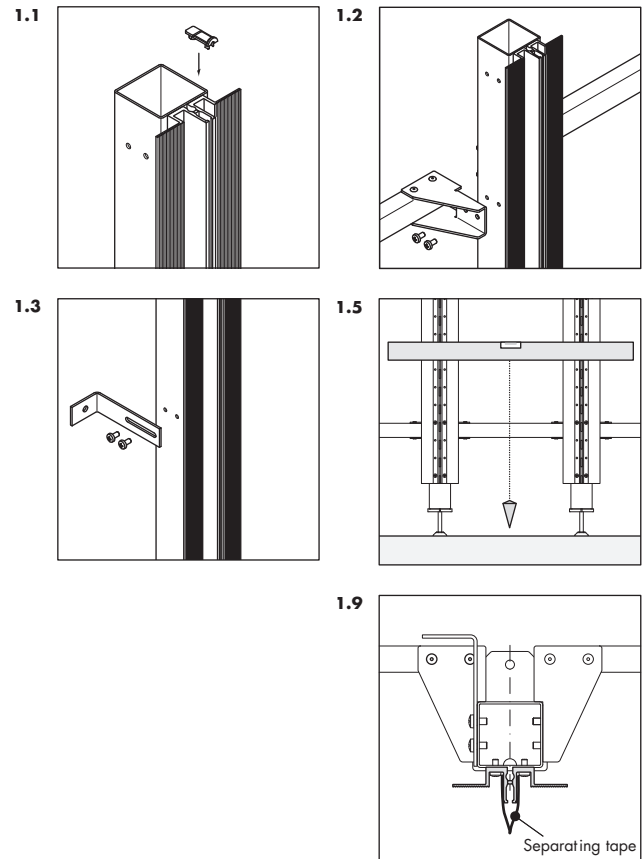
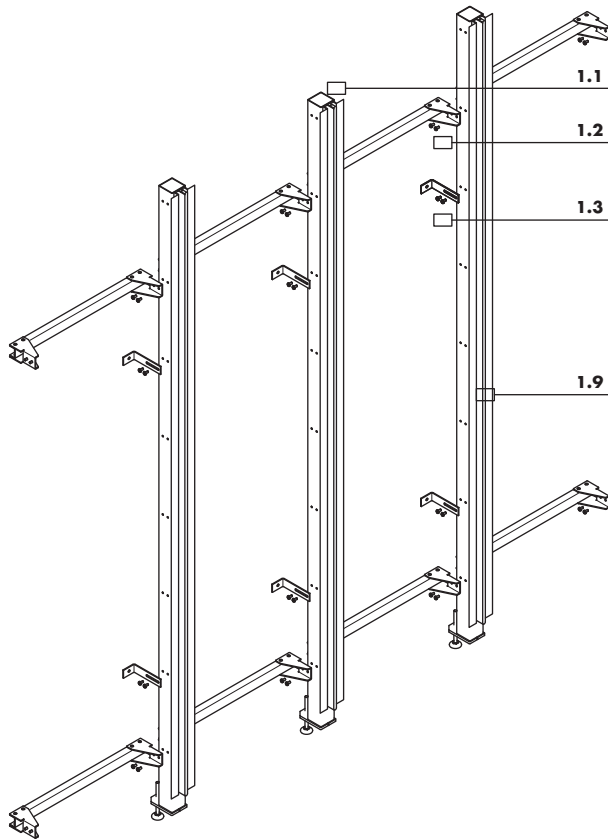

📄 Layout information can be found on the drawing 320-143.

- 1.1 Insert profile end caps 981-479.05 on top and on bottom
- 1.2 The cross-connections are fixed to the side of the system uprights using two M6 x 12 thread grooving screws → do not overtighten screws!
- 1.3 The bracket of the wall attachment kit is attached to the side of the system uprights using two M6 x 12 thread grooving screws → do not overtighten screws! At least 2 brackets are required per upright - the number depends on the condition of the wall.
- 1.4 Assemble the uprights into single unit.
- 1.5 Set up unit, and ensure that it is perfectly aligned in height and that it is perpendicular.
- 1.6 Mark mounting points.
- 1.7 Drill holes in wall and insert dowels.
- 1.8 Reposition wall unit and screw into place. Proceed as described in point 1.5.
- 1.9 Important: Wind separating tape smoothly around the profile (we recommend: Knauf Trenn-fix 65)

⚠ The wall uprights must be screwed to the wall with at least 2 Ø 6 mm screws. The wall and its fixtures must be capable of taking a min. fraction weight of 1.6 kN. Please observe the instructions supplied by the dowel manufacturer.

2. Assembling metal frame

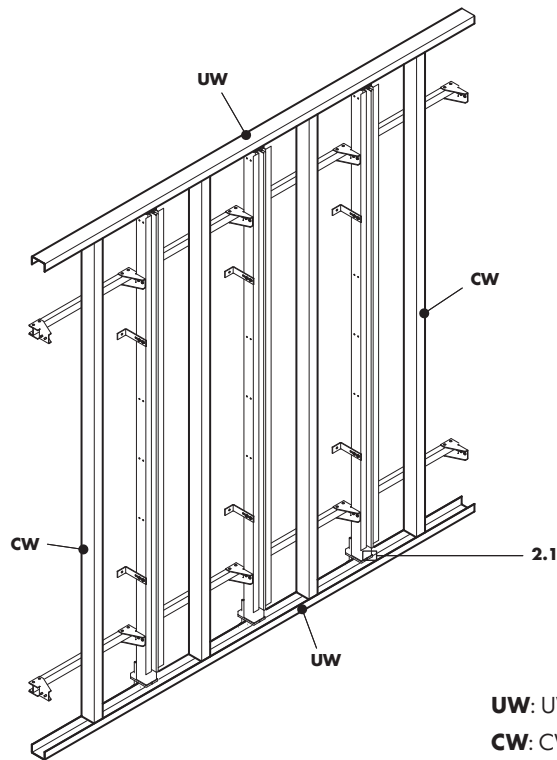

UW: UWprofile UW 75 x 40 mm
CW: CWprofile CW 75 x 50 mm

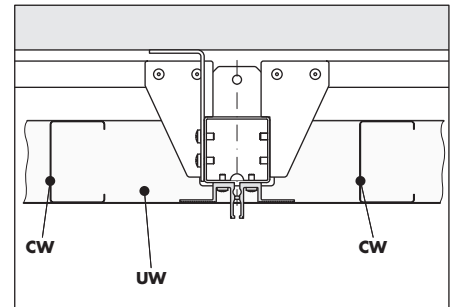

2.1

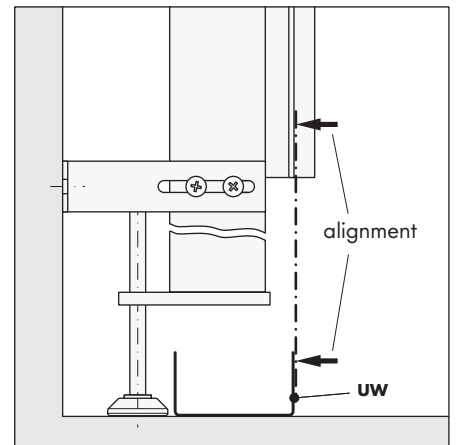

2.1 Set-up metal frame (UW- and CW-profiles): check that profiles are aligned with UW profile. The structure of the wall unit is designed for metal frames with a profile width of 75 mm

Dimensions: plasterboard

- Upright axis: 625 mm
- Depth of panel structure: 142-151 mm
- Layout information can be found on the drawing 320-143

Please observe the indications concerning weight loading and ensure that the substructure of the wall units and their fixtures can support the expected loads

Single plasterboard

Double plasterboard

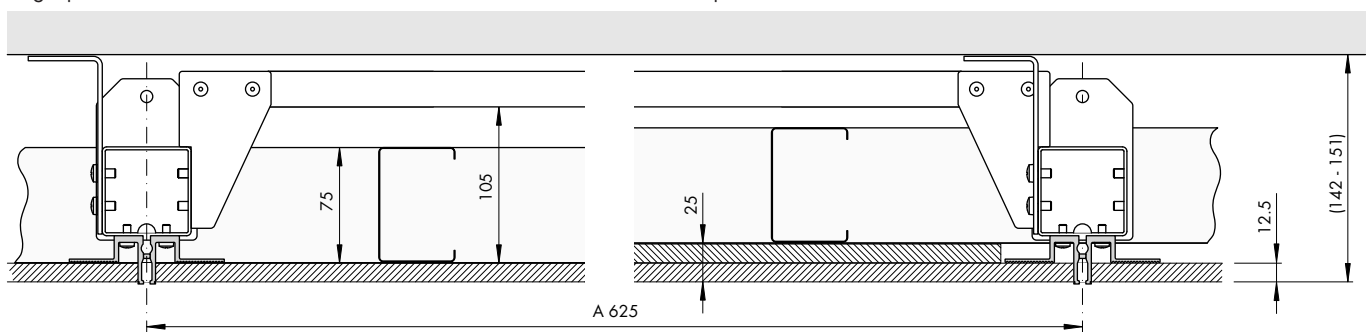

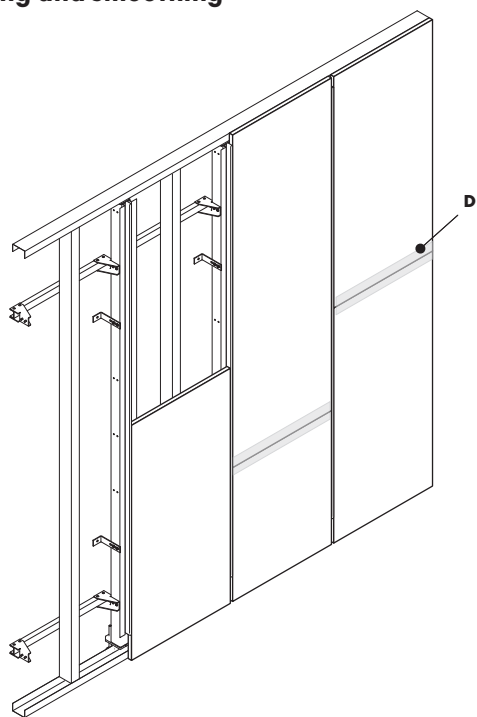
EN 3. Covering and smoothing

3.1 Screw plasterboards to profiles using dry wall screws **A** (e.g. $\text{Ø } 3.9 \times 19 \text{ mm}$). Also screw plasterboards to slotted rails - dry wall screws with drill bits **B** are necessary (e.g. $\text{Ø } 3.5 \times 19 \text{ mm}$).

Recommendations:

- cover joints **C** with reinforcing tape **D**.
- add edge safety profiles if necessary.

Final paintwork (finishing)

3.2 Cut-off protruding strips of separating tape **E**.

3.3 Recommendation:

Apply a finely-structured glass fibre yarn mat to avoid visible cracks.

Cover visible surface of the profile **F** with easily removable masking tape (no residue) before beginning paintwork.

3.4 Final paintwork or other finishes.

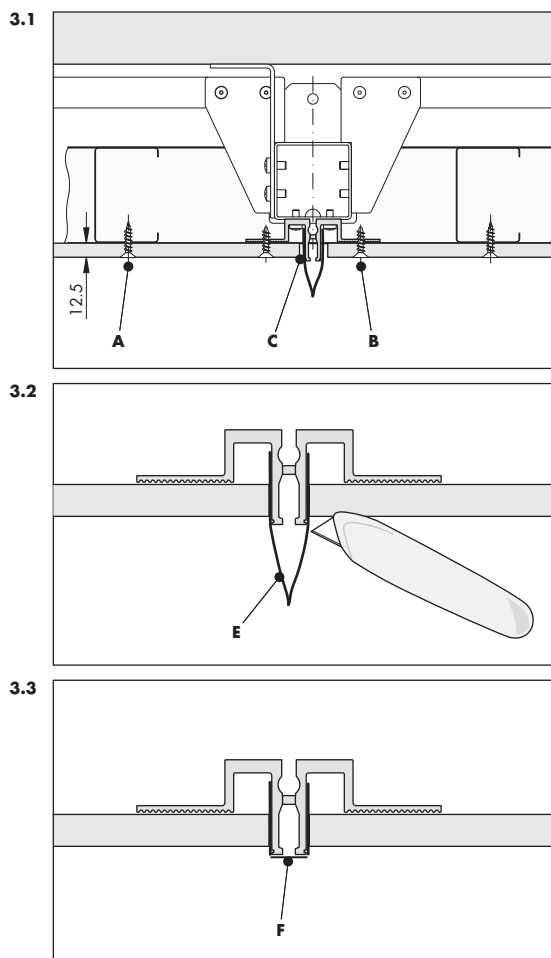

Weight loading

- ⓘ Please observe the permissible weight loading of the accessories used.
 The indicated weight loads are always based on the total weights of the merchandise support and goods.
 Please observe that max. weight loading decreases as the merchandise support increases in length.
 Please observe that the inclination of the merchandise support changes with an increase in load. Different weights on the merchandise supports produce an uneven overall appearance of the goods display.
 The max. weight loading of Xero 4 depends on the nature of the wall, on the number of fixation points as well as on the fixation material used.
 All fixation points are to be used with a maximum weight load.
 Please also observe the weight loads indicated in our sales documentation.

Max. load

Profile	per 1000 mm	100 kg
Front arms Ø 25 mm		25 kg
Front arms 30 x 15 mm		20 kg
Front arms Ø 12 mm		10 kg
Front arms 4 mm		10 kg
Hanging rail 600 mm T arm		20 kg
Hanging rail 390 mm T arm		10 kg
Bracket for wooden shelf	per bracket	15 kg
Bracket for hanging rail Ø 25 mm	per bracket	20 kg
Bracket for hanging rail Ø 25 mm and shelf	per bracket	20 kg
Bracket for hanging rail 30 x 15 mm	per bracket	20 kg
Bracket for hanging rail 30 x 15 mm and shelf	per bracket	20 kg
Bracket for hanging rail 20 x 10 mm	per bracket	10 kg
Bracket for hanging rail Ø 15 mm	per bracket	10 kg
Bracket for glass shelf	per bracket	20 kg
Bracket for wooden shelf	per bracket	20 kg
Clamp bracket for glass shelf		15 kg
Shelf support bracket		20 kg
Hook rail for ties, belts etc.		10 kg

